

# CAPPUCCINO, COFFEE, and SOUP DISPENSERS

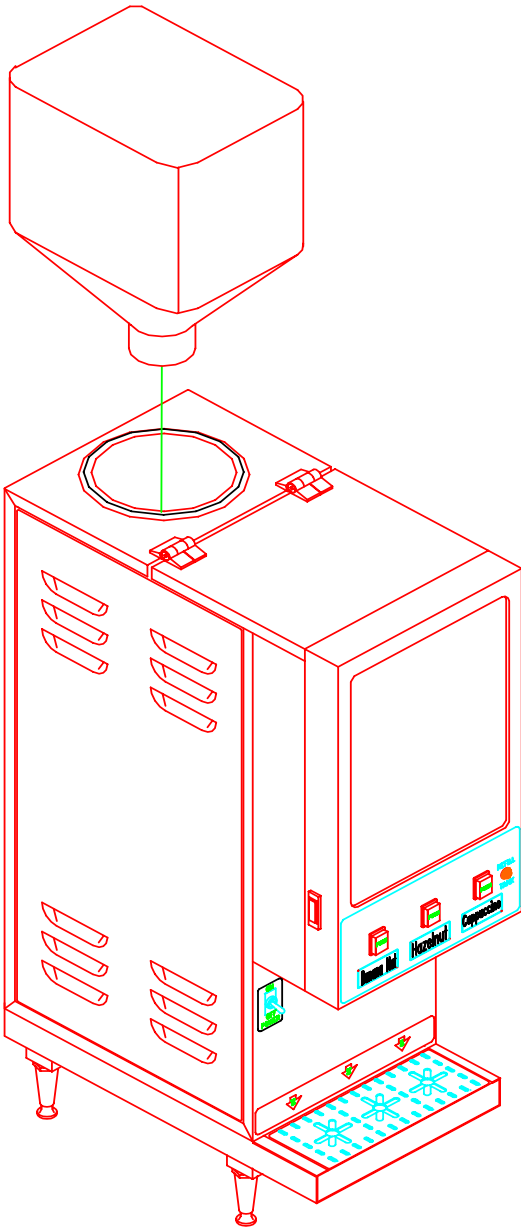

## GB POUROVER models:

- GB1P
- GB2P
- GB3P
- GB4P

## OPERATION MANUAL

• Specifications	2
• Installation and Operating Instructions	3
• Adjustments	4
• Test & Troubleshooting	8
• Maintenance	9
• Cleaning and Sanitizing	10
• Parts Identification & Illustration	11
• Wiring Diagrams	14

**Cecilware sells value... Worldwide**

45 -05 20th Avenue, Long Island City, NY 11105 • 718-932-1414  
FAX 718-932-7860



NI52A-C 12/5/2005

Electrical Specifications								
Model No.	Volts	Phase	Hz	Watts	Number of Heaters	Amps	Receptacle Nema No.	Circuit Breaker
GB1P, GB2P, GB3P GB4P	120V	1	60	1.8KW	1	15	5-15R	15A
GB1P, GB2P, GB3P, GB4P	120/240V	1	50/60	3.0KW	1	15	L14-20R**	20A
	or 240V		50/60	3.0KW		15	L6-20R	20A

120V, 1.8 KW, 15A, Nema 5-15R standard on all models; 3.0 KW, 120/240V units available  
 \*\* 120/240V, 3 pole, 4 wire grounding type Twist-Plug Receptacle.  
 For 240V units, Use L6-20R, 2 pole, 3 Wire Twist-Plug Receptacle.  
 For Wiring, refer to Wiring Diagrams.  
 See Electrical Data Label attached to the back of the unit for proper voltages, breaker sizes and electrical outlet requirements for each model number listed.

Mechanical Specifications									
Model #	No. of Hoppers	Hopper Capacity (lb.)	Width (in.)	Dept (in.)	Hight (in.)	Tank (gal.)	Burst Capacity	Lit Display Area (W x H) sq. in	Ship Weight (lb.)
GB1P-LD	1	4 lb.	8.5	22	31.5	1.5	15	(7X13) 91	70
GB2P-LD	2	4 lb.	8.5	22	31.5	1.5	15	(7X13) 91	75
GB3P-LD	3	4 lb.	11	22	31.5	2	22	(9.5X13) 123.5	90
GB4P-LD	4	4 lb.	14.125	22	31.5	4.5	45	(12.375X13) 123.5	100

Hight: Add an additional 4" when installing with 4" legs.  
 Add an additional 14" min for water bottle and additional height space to invert bottle over the top.  
 \* Burst Capacities - Max. number of drinks dispensable with available hot water - based on 6 oz. cups.  
 \*\* Add 2" for line cord and valve fitting clearance.  
 Plumbing: ¼" water line required.

# START UP INSTRUCTIONS FOR GB POUROVER CAPPUCCINO DISPENSER

(see illustration 9-3 for clarification)

## I. INSTALLATION INSTRUCTIONS

This equipment is to be installed to comply with the applicable Federal, State, or local plumbing codes having jurisdiction.

In addition:

1. A quick disconnect water connection or enough extra coiled tubing (at least 2x the depth of the unit) so that the machine can be moved for cleaning underneath.
2. An approved back flow prevention device, such as a double check valve to be installed between the machine and the water supply.

The GB beverage dispenser is equipped with a ¼" Flare Water Inlet Fitting which is located on the left side in the back of the base (when looking at the machine from the front).

**HIGHLY RECOMMENDED:** A WATER SHUT-OFF VALVE and A WATER FILTER, preferably a combination Charcoal/Phosphate Filter, to remove odors and inhibit lime and scale build up in the machine.

Note: In areas with extremely hard water, a water softener must be installed in order to prevent a malfunctioning of the equipment and in order not to void the warranty.

After the machine has been unpacked and placed on a counter, pull out the stainless steel drip tray. It should contain the following: A Set of 4 Adjustable Leveling Legs & Water Inlet Fitting.

Connect the ¼" dia. copper waterline to the ¼" flare water inlet fitting of the valve.

**Caution:** Do not plug into power outlet yet. Make sure the Heater Switch is OFF (Toggle Down)

## II. PRIMING - MANUAL/BOTTLE POUROVER - Water Selection Switch -Toggle Up (See Back Panel)

1. Do NOT plug into power outlet yet.
2. Make sure Heater Switch is in the OFF position.
3. Fill reservoir tank (top) with 2 gallons of water, wait about 3 minutes for water to fill Heating Tank below. Refill Top Reservoir Tank with another 2 gallons of water. The unit will NOT dispense unless the Top Reservoir Tank is at least 1/2 full. **So keep Reservoir Tank full.**  
**Note: The unit has a Float-low water cutout switch (item 2, III. h-1) inside the Reservoir Tank, which stops the machine from dispensing when the Reservoir Tank is empty.**
4. Plug into power outlet.
5. Turn Heater Switch ON.
6. Allow 10 to 15 minutes for water to reach dispense temperature of 185°F. Heater Indicator Light (red) goes ON when heater is on (see lower front panel).
7. Fill hopper with product.
8. Place cup under dispenser.
9. Push and hold Dispense Button (green) until water flows from mixing chamber.
10. Machine is primed and ready to go.

### III. PRIMING - AUTOFILL - Water Selection Switch - Toggle Down (See Back Panel)

1. Plug into power outlet.
2. Turn Heater Switch ON.
3. Allow 10 to 15 minutes for water to reach dispense temperature of 185°F.  
Heater Indicator Light (red) goes ON when heater is on (see lower front panel).
4. Fill hopper with product.
5. Place cup under dispenser.
6. Push and hold Dispense Button (green) until water flows from mixing chamber
7. Machine is primed and ready to go.

### IV. POUROVER-PORTABLE BOTTLE OPERATION (Water Selection Switch - toggle UP)

Unit Can Be Operated With a 3 Gallons Capacity Fresh Water Bottle.

To Operate With Portable Bottle, proceed as follows:

1. Remove Reservoir Tank Cover.
2. Make sure that Reservoir Tank is only 1/2 full or empty, to prevent water spillage.  
To remove excess water push dispense button.
3. Fill bottle with water .
4. Invert bottle into reservoir tank in one motion to minimize spillage.
5. Remove and refill bottle when "REFILL" light is ON.

**NOTE: REFILL LIGHT, ON THE FRONT DOOR PANEL, WILL GO ON, WHICH INDICATES THAT THE WATER TANK MUST BE REFILLED. WHEN REFILL LIGHT GOES ON, THE UNIT WILL NOT DISPENSE UNTIL TANK IS FILLED WITH WATER. REFILLING WITH HOT TAP WATER WILL SHORTEN HEAT UP TIME.**

### V. NORMAL OPERATION (POUROVER AND AUTOREFILL)

1. Place a 6 oz. or larger cup under the left dispense nozzle, then press and hold the left dispense switch for 6 seconds. The machine will dispense water at the rate of 1 oz. per second. Repeat it several times to check for consistent output.
2. While the tank is heating up, remove the hopper, load with product and reposition it back in the machine.  
When **Ready Light goes ON**, the tank has reached its brew temperature and the machine is ready to begin dispensing the first cup of Cappuccino.

### VI. WATER FLOW ADJUSTMENTS, FLOW RATE

The Unit Is Factory Adjusted To Dispense Water At The Rate of 4 oz/sec.

To increase or decrease flow, proceed as follows:

1. Remove Left side panel and locate Dispense Valve mounted on tank, with Flow Adjuster facing up, underneath cold water reservoir.
2. Locate Flow Adjustment Screw (white) on Dispense Valve. Use Allan Key to reach Flow Adjuster.
3. Rotate Adjustment Screw Counterclockwise to **INCREASE** flow rate.
4. Rotate Clockwise to **DECREASE** flow rate.  
When making adjustments, do not adjust by more than 1/4 turn at a time, without checking output flow or drink strength (ratio of water to powder).

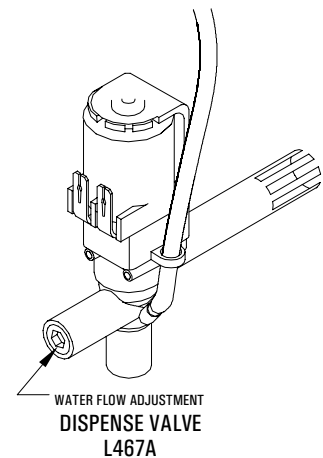

The Dispense Valve is factory adjusted for a maximum flow rate of 1 to 1.3 oz./sec. for coffee and cappuccino. Exceeding 1.3 oz./sec Flow Rate will cause the Mixing Chamber to overflow.

**HOPPER COVER CD106**

**AUGER GEAR – FOR RECTANGULAR HOPPERS:**

CD117 [Used With Nylon Auger CD130]  
CD117 [Used With Wire Auger CD101 & CD130]

**FRONT BUSHING:**

Rectangular Hoppers:  
CD277 [ Ø22.5 mm ]  
CD306 [ Ø17 mm ]

Square Hoppers:

CD102 [ Ø22.5 mm w/O-Ring CD103]  
CD131 [ Ø22.5 mm w/O Ring]

**AUGERS:**

CD130 Nylon Auger [Ø22.5 mm X 17mm Pitch w/O-Ring CD139]  
CD101 Wire Auger [Ø22.5 mm X 17mm Pitch]  
Used for Cappuccino Fast Flow & Soup.

**PRODUCT GUIDE: CD70A**

**DISPENSE CAP: [CD61A White, CD272 Black]**

**MIXING CHAMBER, FAST FLOW: [CD137 White, CD275 Black]**

Correct Water Level, For Max. Flow Rate, when using Nylon Auger [Adjust Water Flow Rate so that the water level reaches almost to the top in the Mixing Chamber]

Correct Water Level, For Max. Flow Rate, when using Wire Auger [Adjust Water Flow Rate so that the water level reaches Half Way Up in the Mixing Chamber]

**DISPENSE NOZZLE: CD67A White**

Nut CD136  
Turn CW  
to unscrew

Triangular Rib

**DRINK STRENGTH ADJUSTMENTS**

**A. Units With Fixed Speed Auger Motors-AC [CD175]**

Fixed Auger Speed [95 RPM] and dispenses powder at a constant fixed rate.

Drink Strength adjustments can be made by adjusting the water flow rate on the Water Dispense Valves. [See section VI]

1. Remove side panel to access the Dispense Valve.
2. Locate Flow Adjustment Screw on Dispense Valve. [See section VI]
3. Rotate adjustment screw Counterclockwise to INCREASE Flow Rate, Clockwise to DECREASE Flow Rate.

(Note: the water flow rate should not exceed 1 to 1.3 oz./sec.)

Do not turn Adjustment Key more than 1/4 turn at a time without checking drink strength (ratio of water to powder).

**B. Units With Variable Speed Auger Motors-DC [CD151] - (OPTIONAL FEATURE)**

Variable Auger Speed [10 to 130 RPM]

Drink or Product Strength adjustments can be made by adjusting the Auger Motor speed.

The Knobs on inside door panel control the amount of product being dispensed [gram throw].

The gram throw is factory preset at 7. Because the consistency of each product varies, the customer can set the desired gram throw for each hopper.

The water flow rate on the Dispense Valves should remain fixed.

Note: the water flow rate should not exceed 1-1.3 oz./sec to avoid spillage from dispense chamber. [See section VI]

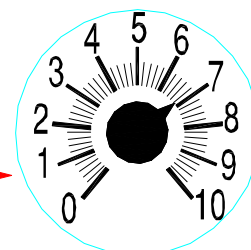

GRAM THROW  
PRODUCT STRENGTH  
ADJUSTMENT

## **DRINK SIZE ADJUSTMENTS (OPTIONAL FEATURE)**

- a. Manual Dispense Machines: Hold down the Dispense Button until desired amount is dispensed.
- b. Automatic Machines with Programmable "Teach me" Timers [L576A or L582A]:  
The timer is programmable from the dispense button.

### **Programming For Automatic Dispense**

1. Turn Power Switch ON (toggle switch inside door).
2. **Press and Hold** [red] **Stop Button** with one hand.
3. **Press and Hold** [green] **Dispense Button** with other hand.
4. **Release** [red] **Stop Button** only.
5. Continue to **Hold** [green] **Dispense Button** for **5 seconds**, then release.
6. **Press and release** [green] **Dispense Button**. Product begins dispensing.  
When it reaches the "desired volume",
7. **Press and release** [green] **Dispense Button** to set "desired volume".  
**Dispense Button** can be "jogged" to top off.
8. **Press and release** [red] **Stop Button** to lock in "desired volume".  
Repeat steps 1 to 8 for each Dispense Button.

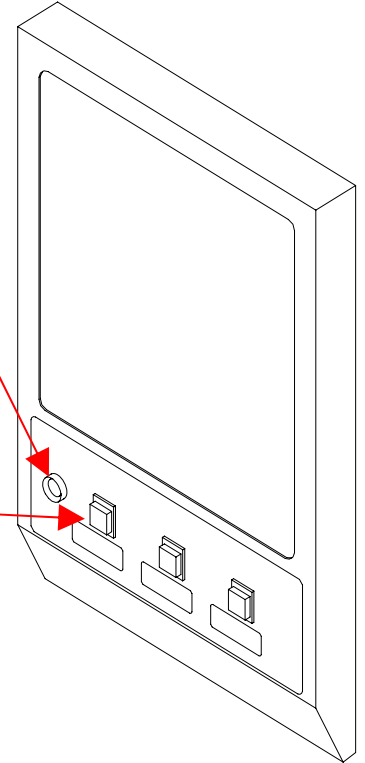

### **Programming Instructions For Manual Dispense**

1. **Press and Hold** [red] **Stop Button** with one hand.
2. **Press and Hold** [green] **Dispense Button** with other hand.
3. **Release** [red] **Stop Button** only.
4. Continue to **Hold** [green] **Dispense Button** for **5 seconds**, then release.
5. **Press and release** [red] **Stop Button**.

The total time the water is running is accumulated and saved into memory. For normal operation, Press and Release Dispense Button.

The Timers Have Been Factory Preset for 6 oz. Cups for Coffee; For 8 oz. Cups for Soup and Cappuccino. To Change To Larger Or Smaller Cup Sizes [Volumes] Repeat Steps 1 To 8 Above.

### **To Check Volume And Gram Throw Dispensed (ratio):**

1. Remove the product guide from the hopper and position a receptacle under the hopper nozzle to catch the gram throw of product. Also place a measuring cup under extension tube to catch the water dispensed.
2. Push the dispense button and check the amount of product dispensed, amount of water dispensed, and time [use stop watch] to dispense that water.
3. The amount of water dispensed in the measuring cup divided by the amount of time to dispense that water is the Water Flow Rate from Dispense Valve.

**For Cappuccino:** The machine is factory adjusted to dispense 4-4.5 gr./sec. per OZ. Cup. [32 g Product per 8 oz. cup]  
The recommended throw is 28-32 grams per 8 oz. cup for Cappuccino, with 80% fill.

**For Coffee:** The machine is factory adjusted to dispense 0.3 gr./sec per OZ. Cup. [1.5 grams of coffee product per 5 oz. of liquid (in a 6 oz. cup). The recommended throw is 1.5 to 1.8 grams per 6 oz. cup of Coffee, with 80% fill.

**For Soup:** The machine is factory preset to specified customer requirements, because the gram throw for each soup flavor and type varies considerably with the consistency of each product. Adjustments can be made by the customer.

## TEST

### A) Water Inlet Valve Test

Turn power off. If the water level rises inside the tank, the Water Inlet Valve is leaking. Disconnect wires from the Water Inlet Valve coil and connect a 2 wire line cord to the terminals. Plug it into a 115V outlet. If water flows in and stops when you pull it out, the Valve is working fine. Repeat this test a few times. The problem may be in the Probe or Water Level Control Board. If the water does not flow in when the cord is plugged into an electrical outlet, the Solenoid coil may be damaged, opened or the valve may have an obstruction preventing the water from flowing in. Clean or replace it.

A Check Valve is installed to prevent backflow.

To check proper function of Check Valve, disconnect water line from the Check Valve, check for dripping from the disconnected end of the Check Valve. If it leaks replace it.

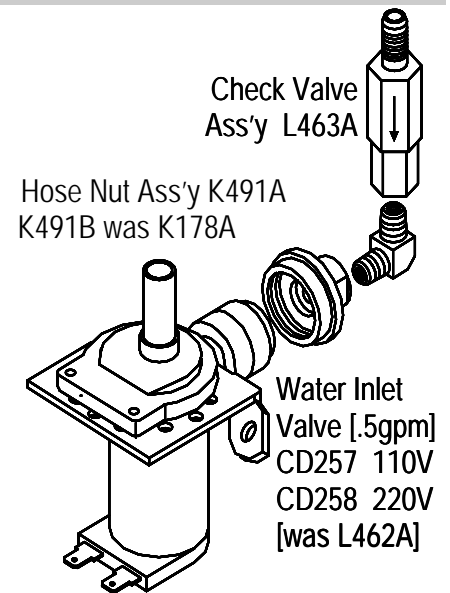

### B) Hi-Level Float Switch Test

The Float Switch acts as a guardian for the Solid State Level Control Board and its Probe. If they malfunction and cause the water inside the tank to rise, the Float Switch will prevent flooding by terminating the power to the Solid State Control Board and the Water Inlet Valve. The correct mounting position of the Float Switch in the tank is as shown in picture, with the magnets in the Float Switch in the upper part of the switch.

After tank is full, unplug the wire to the Level Control Probe, the water should run into the tank for a few more seconds until it reaches the Float Switch and it should stop. If not, and water starts coming out of the Breather tube, the Float Switch is malfunctioning.

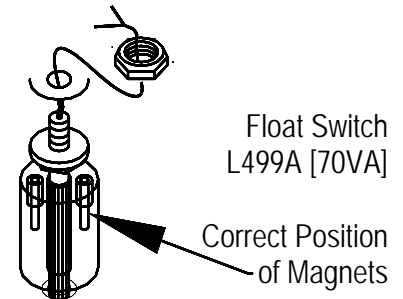

### C) Probe Test

If lack of water persists, check the probe as follows: Turn on the power and water supply. Check inside the tank to make sure the water is not touching the Probe. Pull wire and terminal out of the Probe rod. If water still does not flow after the wire is disconnected from the Probe, the problem may be in the Solid State Water Level Control Board. If water starts flowing into the tank, the Probe may be grounded, due to excessive liming. Check with Ohm meter. Clean or replace probe.

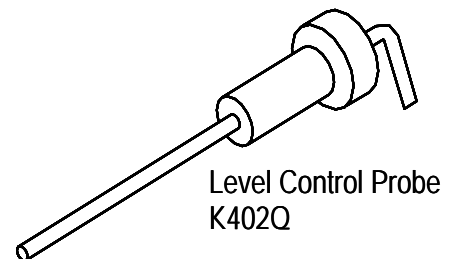

### D) Solid State Water Level Control Board Test

Check the Board as follows:

1. Make sure there is power input to the Board at the terminals 2 & 3. Your voltmeter should read 115 Volts. It should read the same at terminals 1 & 3. This is the output power to electrify the coil of the Solenoid Valve to open it. The lack of voltage at terminals 2 & 4 will indicate that the Board is not working properly.
2. Make sure all wire connections to the Board are tight.
3. The grounding plate at the top, in the back of the board should be securely grounded. The Board will not work or will work erratically, if it is not grounded properly. If after this, the Board is still failing to open the Water Inlet Valve, replace it.

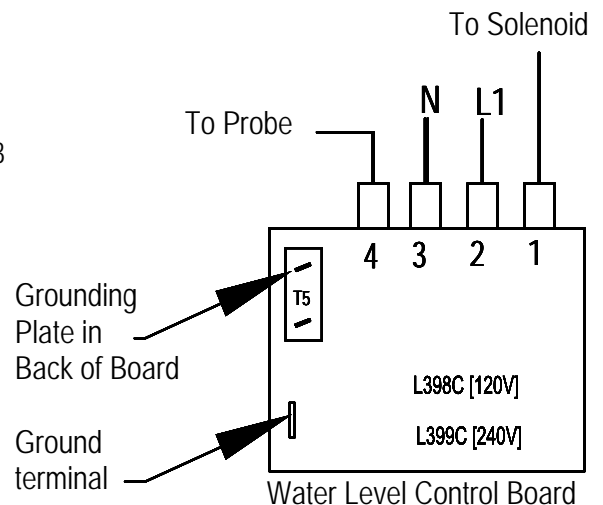

## TROUBLESHOOTING GUIDE FOR GB-POUROVER

**WARNING:** To reduce the risk of electrical shock unplug the dispenser power cord before repairing or replacing any internal components of the unit.. Before any attempt to replace a component be sure to check all electrical connections for proper contact.

PROBLEM		PROBABLE CAUSE	REMEDY
1 Light Display not lit. No power.	A	Dispensing unit unplugged	Reconnect dispensing unit
	B	No power from Terminal Block	Check the Terminal Block for loose wire
	C	Defective Bulb	Replace Bulb.
	D	Defective Ballast.	Replace Ballast.
	E	Loose Bulb in socket.	Make sure bulb is seated properly in socket.
2 No water when Rinse Switch is ON.	A	Water supply OFF.	Turn water ON.
	B	Clogged inlet screen (Water Inlet Valve).	Disconnect water line and clean inlet screen.
	C	Inoperative Water Inlet Valve.	Check connection, if needed replace Valve.
	D	Loose electrical connection.	Check all electrical connections.
3 No product when Dispense Button is pressed	A	No product in Hopper.	Add product.
	B	Auger not working.	Engage Hopper/Nut to Motor Gear (See section VI).
	C	Damaged, loose, or missing Agitator Gear.	Replace Agitator/Auger Gear (See section VI).
	D	Inoperative Auger Motor or Relay.	Check connections of Motor, Relay and/or Switch, if needed replace components.
	E	Hopper outlet clogged	Clean Hopper and check Cartridge Heater.
	F	Faulty Coupling.	Replace damaged Coupling components.
4 Water does not shut off. Water keeps dispensing.	A	Leaking Water Inlet Valve.	Clean/check fittings of Water Inlet Valve. Replace Water Inlet Valve if needed. See "Water Inlet Valve Test"
	B	Inoperative Dispense Switch	Check Switch connections. Replace Dispense Switch if needed.
	C	Inoperative Rinse Switch	Check Rinse Switch connections. Replace Rinse Switch if inoperative.
	D	Clogged/stuck Water Dispense Valve	Clean or unclog Water Dispense Valve. Replace Dispense Valve if inoperative.
5 Water is not heating up in the HOT water tank.	A	Heater Switch is OFF.	Turn Heater Switch ON.
	B	Thermostat is OFF.	Turn Thermostat ON. Turn Knob Clockwise.
	C	Loose connection on Thermostat.	Make sure all wires and terminals on Thermostat are tight.
	D	Hi-Limit Temperature Switch is defective	Replace the Hi-limit.
	E	Heater is burned out or defective.	Replace the Heater.



## MAINTENANCE

### To Replace The Picture / Duratran GB w/ Metal Doors Only:

Lift up the two end tabs on top of door with a pointed object or flat head screwdriver.

Pull the entire picture frame out. Open up the two clear panels and replace picture.

Tuck clear plastic panel inside bracket at top.

**Be sure to tuck clear panel under bracket before sliding frame ass'y inside door. The longer metal tab side goes in the front.**

### To Replace The Fluorescent Bulb:

Remove the upper inside door panel. Turn the lamp and pull it out of the lamp holder, then place the new lamp into the lamp holder and turn it until it snaps into position.

### To Replace The Starter:

Remove the upper inside door panel, turn the starter slightly counter-clockwise and take it out of the starter base. To install the new starter, snap the starter into the starter base and turn it slightly clockwise into position.

## RECOMMENDED PREVENTIVE MAINTENANCE

### 1. Check All Chamber Mounts For Signs Of Wear

- A. Product Running Down The Front Of The Unit.
- B. Product Built Up On The Back Of Chamber Mount.  
Remove Chamber Mount.  
Clean And Re-Lubricate Motor Shaft  
Using Food Grade Lubricant Only  
Replace With New Chamber Mount.

### 2. Clean Out Vent Motor, Trough And Tubing.

- Lift up black tabs, remove Trough Drawer, Clean, and replace Trough Drawer.
- Remove Hose Assembly From The Motor.
- Clean Out And Replace.

### 3) Check All Dispense Valves For Lime Build-Up.

Drain The Water Tank To Just Below The Level Of The Dispense Valves.

Remove The Valves And Clean.

( You Can Take These Valves Apart By Hand As Shown).

Replace The Assembly As Needed (L467A).

Replace The Valve Into The Tank And Refill tank.

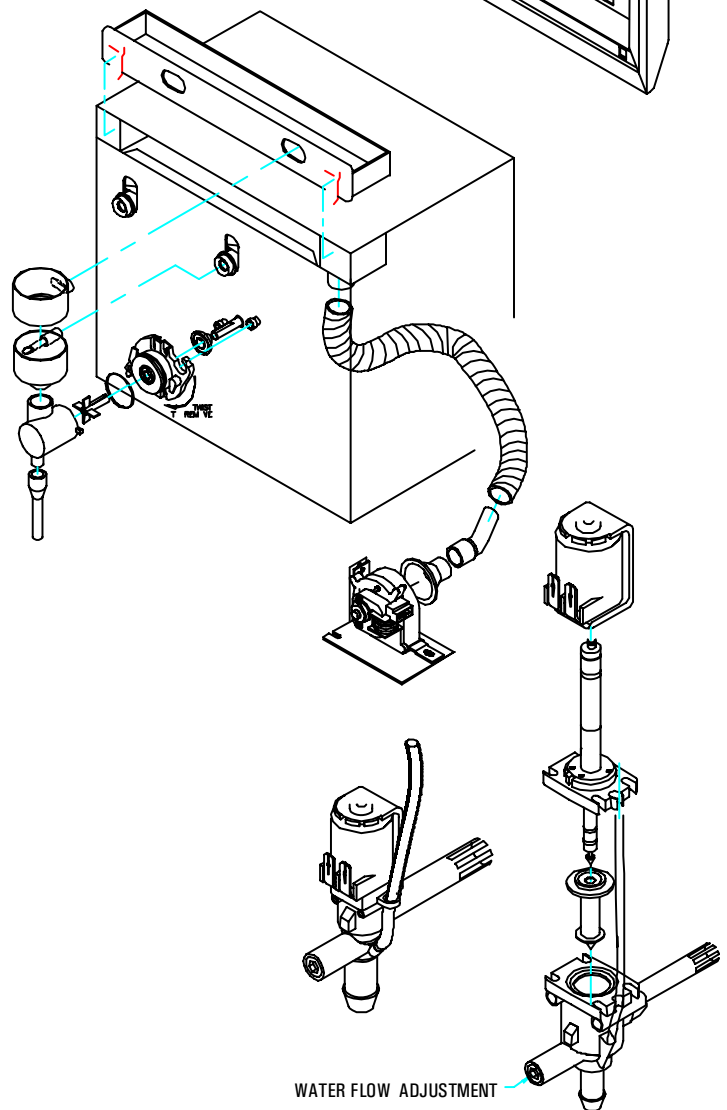
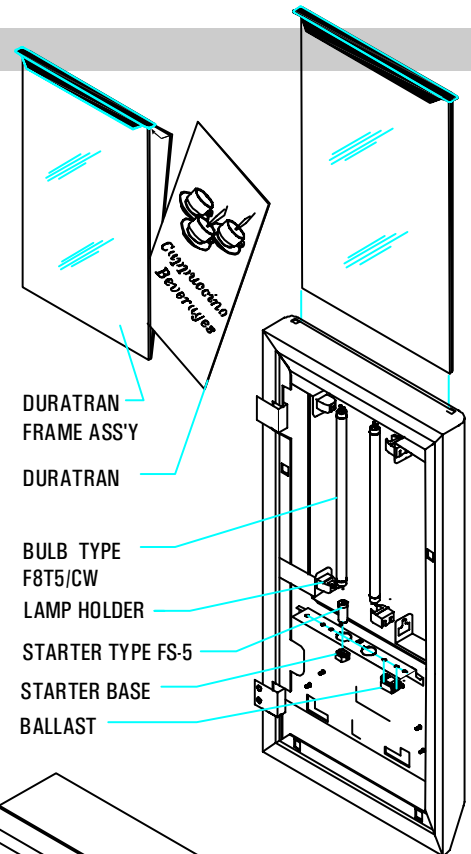

## CLEANING AND SANITIZING

**Sanitizing:** All sanitizing agents in the food zone must comply with 21 CFR 178.1010.

All food dispensing units should be sanitized periodically. All parts to be sanitized must be cleaned first.

**To prepare a sanitizing solution:**

**Add 2 Tsp. Of Liquid Clorox Bleach (5.25% Concentration) To 1 gallon Of Water At Room Temperature (70°- 90°F).**

**Note: Always start with a unopened bottle of Clorox Bleach since the solution from an opened bottle has a short life span.**

- Soak all parts for a minimum of 3 min. in the sanitizing solution.
- Let all sanitized parts drain and dry naturally. **DO NOT WIPE THEM DRY.**
- Before using the sanitized unit (or parts) with food stuffs, rinse all parts thoroughly with water.

Water pipe connecting and fixtures directly connected to a potable water supply shall be sized, installed, and maintained in accordance with Federal, State, and Local codes-section 7.

### Cleaning

1. Turn the power switch to OFF.
2. Remove the drip tray with grill and empty the contents.
3. Wash and let dry the tray and grill (use a mild dishwasher detergent).
4. Wash and let dry the dispense area.
5. Turn the power switch to ON.

### **Cleaning the Hoppers (See Hopper Illustration section VI)**

1. Open the cabinet door and raise the top cabinet lid.
2. Take the hopper out of the cabinet.
3. Pull off the elbow chute and remove the hopper cover.
4. Unscrew the auger gear CW while holding steady the auger inside the hopper. Take out the auger, agitator wheel, and spring.
5. Rinse each item thoroughly.
6. Let dry all items and reassemble.

### **Filling the Hoppers**

1. Open the cabinet door, raise the top cabinet lid.
2. Fill each hopper with the correct product. **Note: Hoppers can also be removed for filling.**
3. Reposition hoppers in the hopper compartment, making sure the hoppers are properly seated.

### **Flushing the Whipper Chamber**

1. Open the cabinet door and turn the RINSE switch to ON.
2. Place a container under each dispense nozzle and push the dispense switches.  
**Note: On manual dispense machines, push and hold the dispense buttons for 10 seconds.**
3. Open the cabinet door and turn the Rinse switch back to OFF.
4. Wash and let dry the splash panel.
5. Remove the drip tray, wash and let dry thoroughly.

### **Removing and Cleaning the Cappuccino Whipper Chambers (See Hopper Illustration section VI)**

1. Remove the dispense cap by pulling it forward and at the same time twisting it clockwise.
2. Grab and pull the mixing bowl out of the mixing bowl socket.
3. Grab and twist the whipping chamber clockwise and pull it off the mounting plate.
4. Pull the Whipper blade off the motor shaft. Notice the flat keyway on the shaft and the matching keyway inside the Whipper blade shaft.  
It is important that these two keyways are lined up when re-assembling the components.
5. Twist the mounting plate clockwise and pull it off the motor shaft.
6. Slip off the o-ring from the Whipper chamber mounting plate and clean o-ring and o-ring seat.

### **Removing and Cleaning the Coffee/Tea Mixing Chambers (See Hopper Illustration section VI)**

1. Remove the dispense cap.
2. Pull the mixing bowl out of the mixing bowl socket.
3. Take out the extension tubes.
4. Rinse them thoroughly

## RESERVOIR AND TANK ASSEMBLY

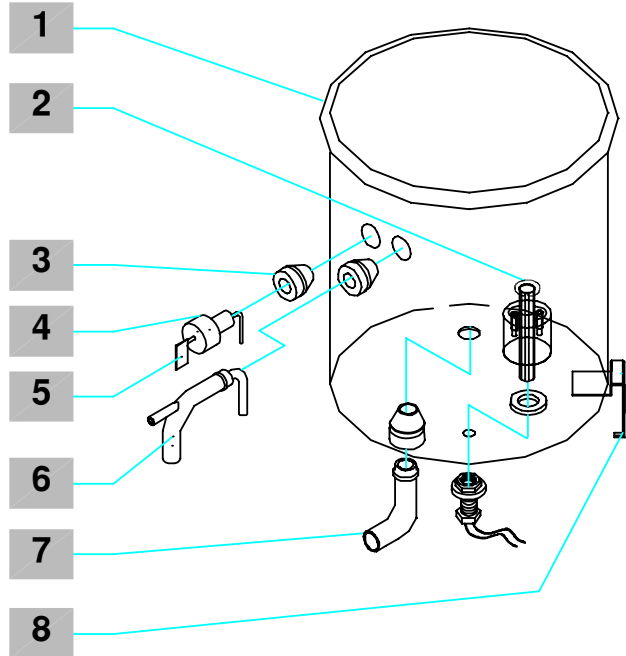

Q174Q RESERVOIR ASSEMBLY			
ITEM	P/N	QTY	DESCRIPTION
1.	Q174A	1	P.O.-LINE TANK(GB3M/CAP)
2.	L499P	1	FLOAT SWITCH 70-V-A
3.	M461A	3	DIRECT MOUNTING SEAL (.466 ID)
4.	K402A	1	LEVEL CONTROL,
5.	P410A	1	PROBE SEAL
6.	K535A	1	LEVEL CONTROL PROBE
7.	K525A	1	ELBOW ASS'Y-1/2" OD S.S. 90°
8.	RI71A	1	UPPER TANK MOUNT BRACKET

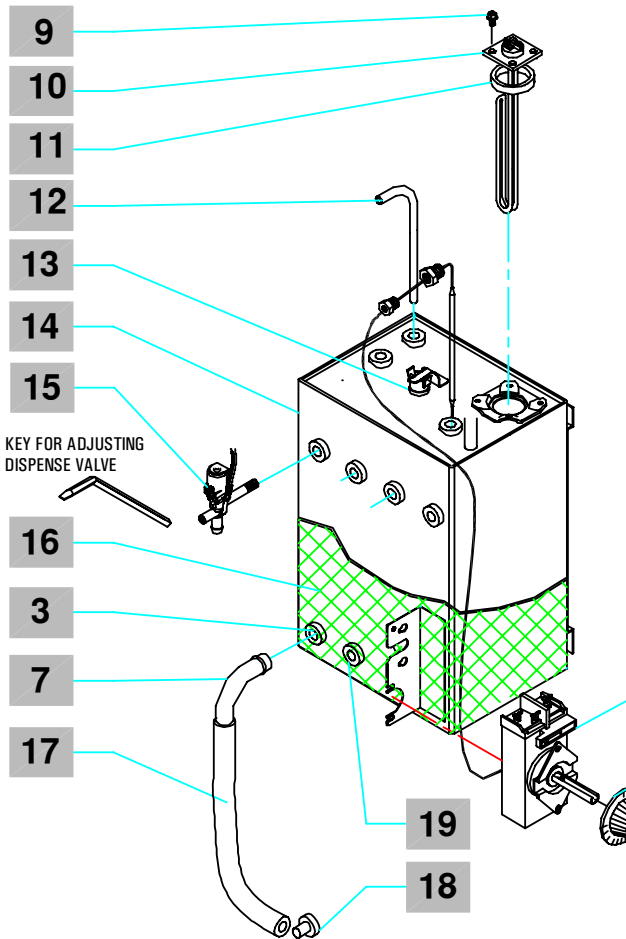

HOT WATER TANK ASSEMBLY			
ITEM	P/N	QTY	DESCRIPTION
9	P446A	4	1/4-20x5/8 SS SL HEX WASHER HD SCR
10	G194A	1	HEATER 120V, 1700W
11	MO18A	1	GASKET, TANK HEATER
12	K537A	1	INLET TUBE, 1/2" OD SS 8" L
13	L656A	1	HI-LIMIT
14	RZ53Q	1	TANK WELDMENT ASS'Y
15	L467A	3	DISPENSE/DUMP VALVE
16	M601A	1	TANK INSULATION
17	M545A	1	DRAIN HOSE
18	M391A	1	DRAIN END PLUG
19	M455A	1	SEAL PLUG, SILICONE
20	M008A	1	THERMOSTAT KNOB
21	L532A	1	THERMOSTAT

# DESCRIPTION AND LOCATION OF COMPONENTS (GB3P SHOWN)

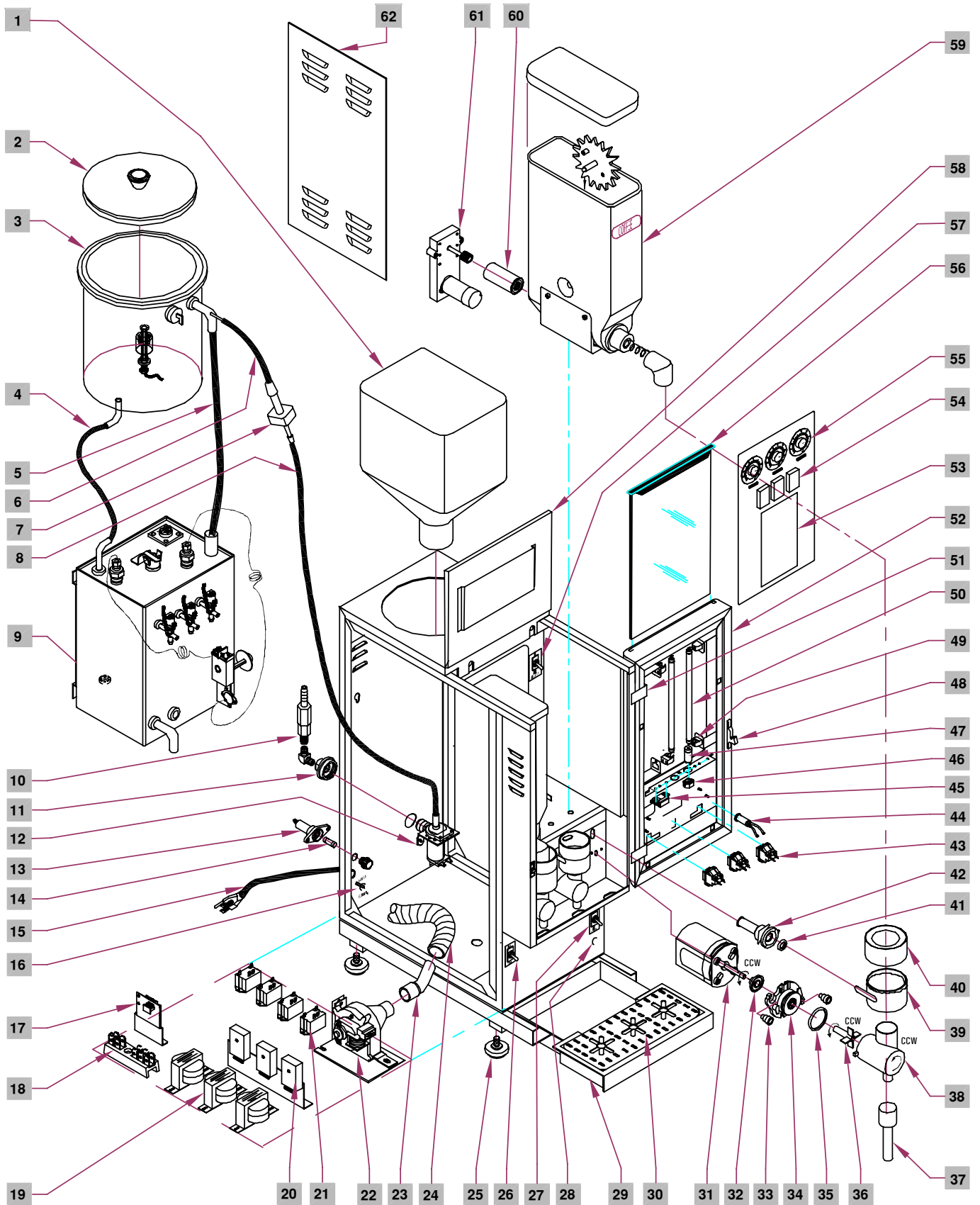

ITEM	DESCRIPTION	GB1P	GB2P	GB3P
1	WATER BOTTLE 3 gal / OR 6 gal	M518A / M519A	M518A / M519A	M518A / M519A
2	RESERVOIR /COVER	97128	97128	97128
3	RESERVOIR ASSY	Q174Q	Q174Q	Q174Q
4	SILICONE HOSE - RESERVOIR TO TANK	M540A	M540A	M540A
5	SILICONE HOSE - BREATHER TUBE TO BREATHER TUBE	M541A	M541A	M541A
6	SILICONE HOSE - HOSE BARB TO RESERVOIR	M542A	M542A	M542A
7	HOSE BARB, REDUCER	K534A	K534A	K534A
8	SILICONE HOSE - WATER INLET VALVE TO HOSE BARB	M543A	M543A	M543A
9	TANK WELDMENT ASS'Y (F/HOT WATER)			RZ53Q
11	HOSE NUT ASS'Y BRITISH-K491B	K178A/K491A	K178A/K491A	K178A/K491A
12	WATER INLET VALVE	L462A/CD257	L462A/CD257	L462A/CD257
13	FUSE HOLDER [USED WITH 120/240 ONLY]	C396A	C396A	C396A
14	FUSE BUSMAN SC15 [Used W/120/240 Only] ] [Or Stepdown Transformer 240/120 CE187]	CE181	CE181	CE181
15	POWER/ ELECTRICAL CORD 240V-C770A	C035A/C032S	C035A/C032S	C035A/C032S
16	SWITCH, WATER SELECTION - POUROVER/AUTOFILL	L069A	L069A	L069A
17	WATER LEVEL SENSOR (CCA) 240V-L399A	L398A	L398A	L398A
18	TERMINAL BLOCK 120V / OR 240V	B117A / B116A	B117A / B116A	B117A / B116A
19	TRANSFORMER [USED WITH DC MOTORS & SPEED CONTROL TIMERS- OPTIONAL]	CF29A [1]	CF29A [2]	CF29A [3]
20	SPEED CONTROL TIMERS [CONTROLS AUGER SPEED, GRAM THROW - OPTIONAL]	L556A [1]	L556A [2]	L556A [3]
21	RELAYS (NO)+ RELAY (NO/NC ) [RELAYS NOT USED WHEN USING TEACH-ME TIMERS]	B129A (1) + B138A (1)	B129A (2) + B138A (1)	B129A (3) + B138A (1)
22	BLOWER DRYER	CD56A	CD56A	CD56A
23	ELBOW INSERT	CD108	CD108	CD108
24	BLOWER DUCT HOSE 16" x (1" DIA)	CD107	CD108	CD107
25	LEGS (SET OF 4)	M172A	M172A	M172A
26	POWER SWITCH (120 V) OR / (120/240 V)	L069A / L299A	L069A / L299A	L069A / L299A
27	RINSE SWITCH	L446A	L446A	L446A
28	HEATER INDICATOR LIGHT (amber)	C002A	C002A	C002A
29	DRIP TRAY GRILL	RI23A	RI18A	RI19A
30	DRIP TRAY PAN	RI11A	RI11A	RI12A
31	WHIPPER MOTOR short shaft	CD75A	CD75A	CD75A [3]
32	SLINGER DISC	CD126	CD126	CD126 [3]
33	CHAMBER MOUNTING GROMMET	CD66A	CD66A	CD66A [6]
34	CHAMBER MOUNT	CD65A	CD65A	CD65A [3]
35	"O" RING # 125 (used w/ grommet)	M379A	M379A	M379A [3]
36	WHIP BLADE	CD64A	CD64A	CD64A [3]
37	EXTENSION TUBE	M467A	M467A	M467A [3]
38	WHIP CHAMBER	CD63A	CD63A	CD63A [3]
39	MIXING CHAMBER	CD62A	CD62A	CD62A [3]
40	DISPENSE CAP	CD61A	CD61A [2]	CD61A [3]
41	"O" RING (#110) (used w/ socket CD67A)	M378A	M378A	M378A [3]
42	MIXING BOWL SOCKET	CD67A	CD67A [2]	CD67A [3]
43	DISPENSE BUTTON / SWITCH	L455A	L455A	L455A [3]
44	REFILL TANK INDICATOR LIGHT	C072A	C072A	C072A
45	BALLAST	CE221	CE221	CE221 [2]
46	STARTER BASE (for lamp inside door)	B128A	B128A	B128A [2]
47	STARTER, TYPE FS - 5, 5-6-8 WATT	L396A	L396A	L396A [2]
48	LAMP HOLDER	CE220	CE220	CE220 [4]
49	DOOR LATCH	M367A	M367A	M367A
50	BULB, TYPE F8T5/CW	CE76A	CE76A	CE76A [2]
51	HIDDEN HINGES [1SET]	K618A	K618A	K618A
52	DOOR WELDMENT ASSEMBLY, less components	RD03Q	RD03Q	RD02Q
53	MAINTANANCE INSTRUCTIONS	N978A	N978A	N978A
55	POTENTIOMETERS	L557A [1]	L557A [2]	L557A [3]
56	DURATRAN HOLDER ASS'Y	SB98A	SB98A	RX48A
57	HEATER SWITCH, 30A SPST (120V) OR / (120/240V)	L069A / L299A	L069A / L299A	L069A / L299A
58	TOP COVER, FRONT	RC96A	RC96A	RC80A
59	HOPPER ASS'Y WITH NYLON AUGER / OR WITH WIRE AUGER	CD99A / CD161 [1]	CD68A / CD98A [2]	CD68A / CD98A [3]
60	NUT (FLANGE)	CD136	CD136	CD136 [3]
61	AUGER MOTOR (90 RPM)	CD150	CD150	CD150 [3]
62	SIDE PANELS	RH91A	RH91A	RH91A [2]

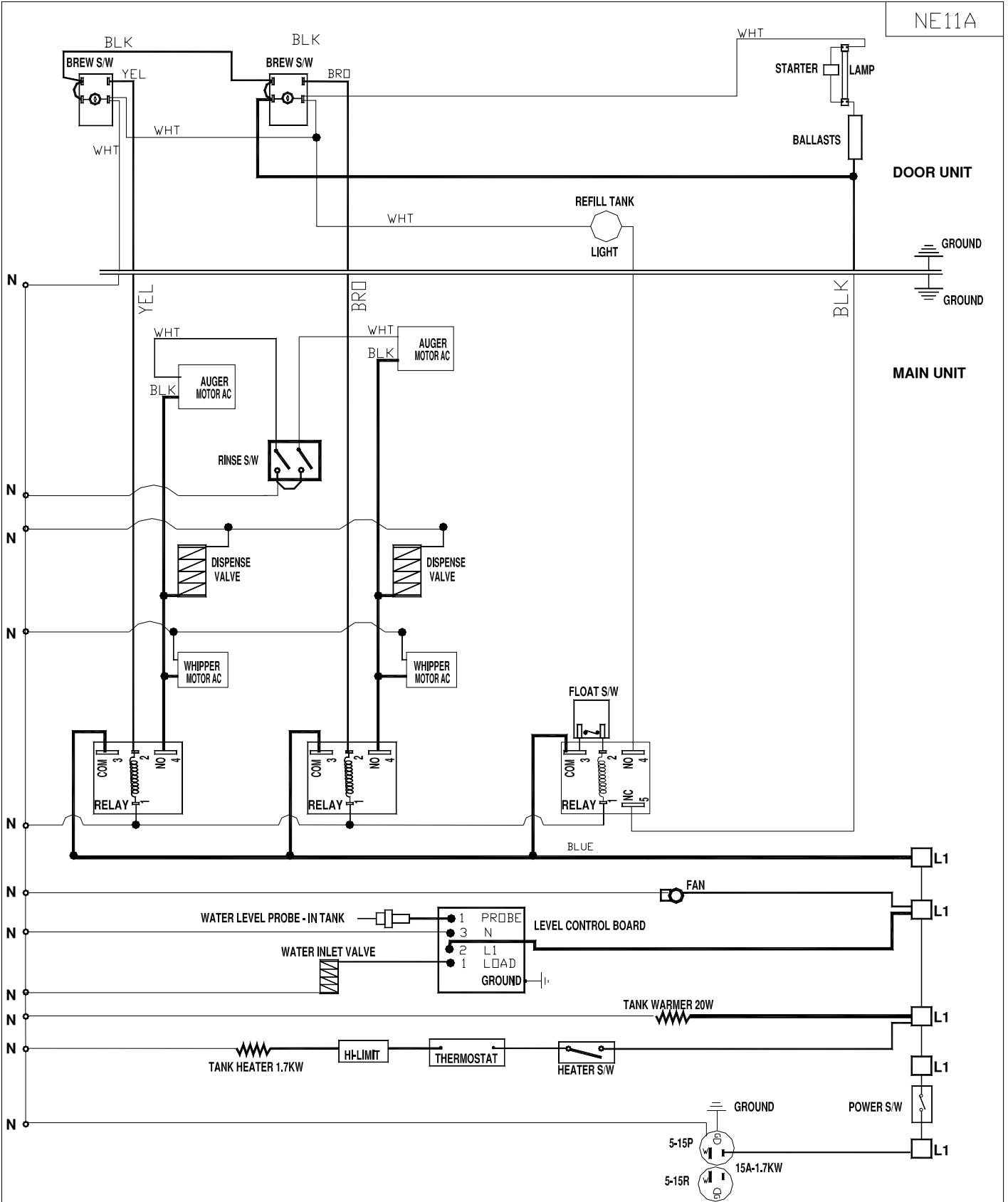

REV	BY	DATE	DESCRIPTION	APPROVED BY	DATE	PART NO. NE11A
MATERIAL:	N/A			DRAWN BY C.G.	DATE 6/17/97	SCALE N T S
CECILWARE CORPORATION				43-05 20 AVE. L.I.C. NY 11105		
TITLE: ELECTRICAL DIAGRAM GB2P [120V, 1.7KW, 1 PH, 2 WIRES + GROUND] W/RELAYS						REV.

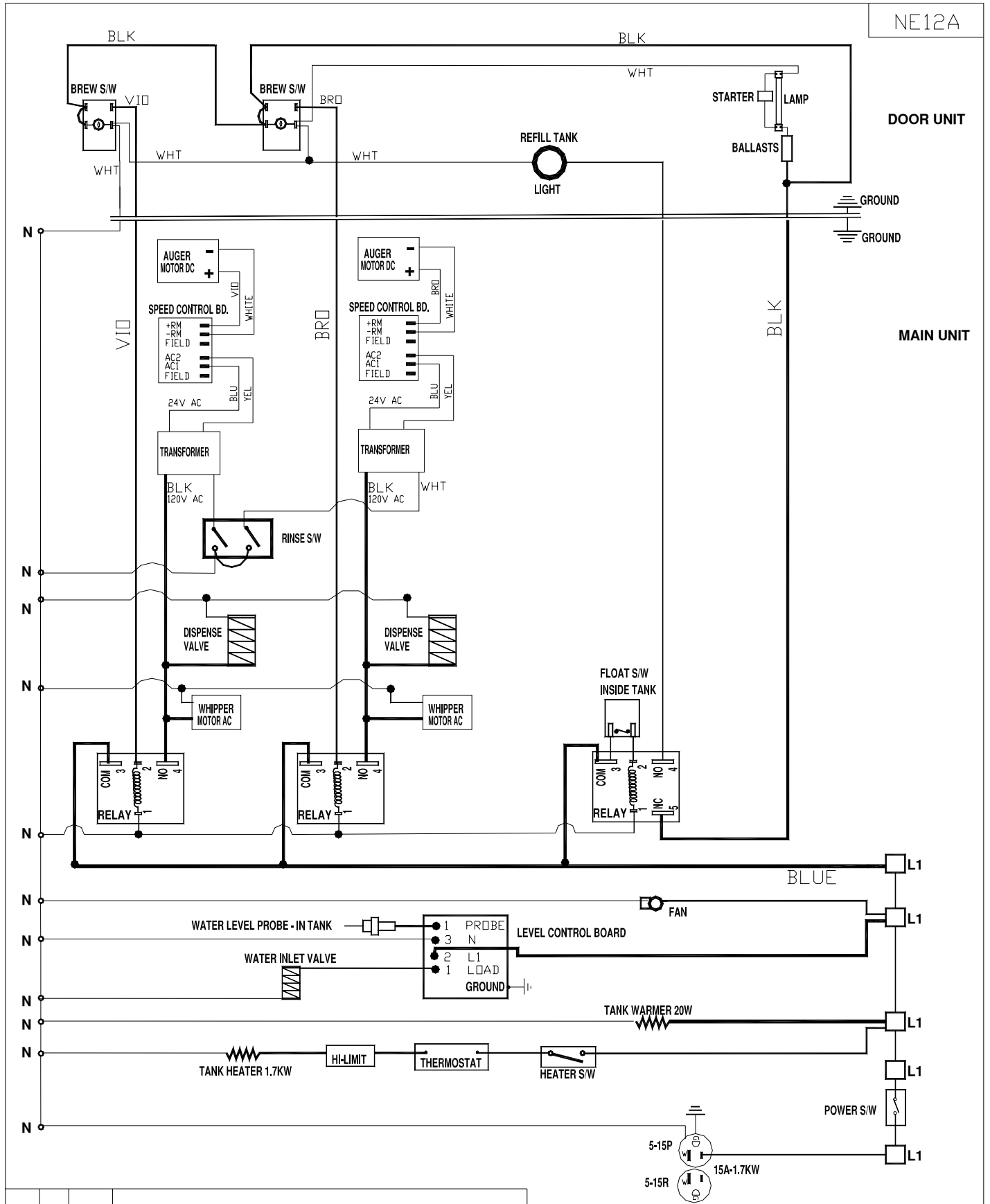

REV	BY	DATE	DESCRIPTION	APPROVED BY	DATE	PART NO.
						NE12A
MATERIAL: N/A				DRAWN BY: C.G.	DATE: 6/17/97	SCALE: N T S
CECILWARE CORPORATION			43-05 20 AVE. L.I.C. NY 11105			
TITLE: ELECTRICAL DIAGRAM GB2P [120V, 1.7KW, 1 PH, 2 WIRES + GROUND] W/ RELAYS, SPEED CONTROL BOARDS						REV.

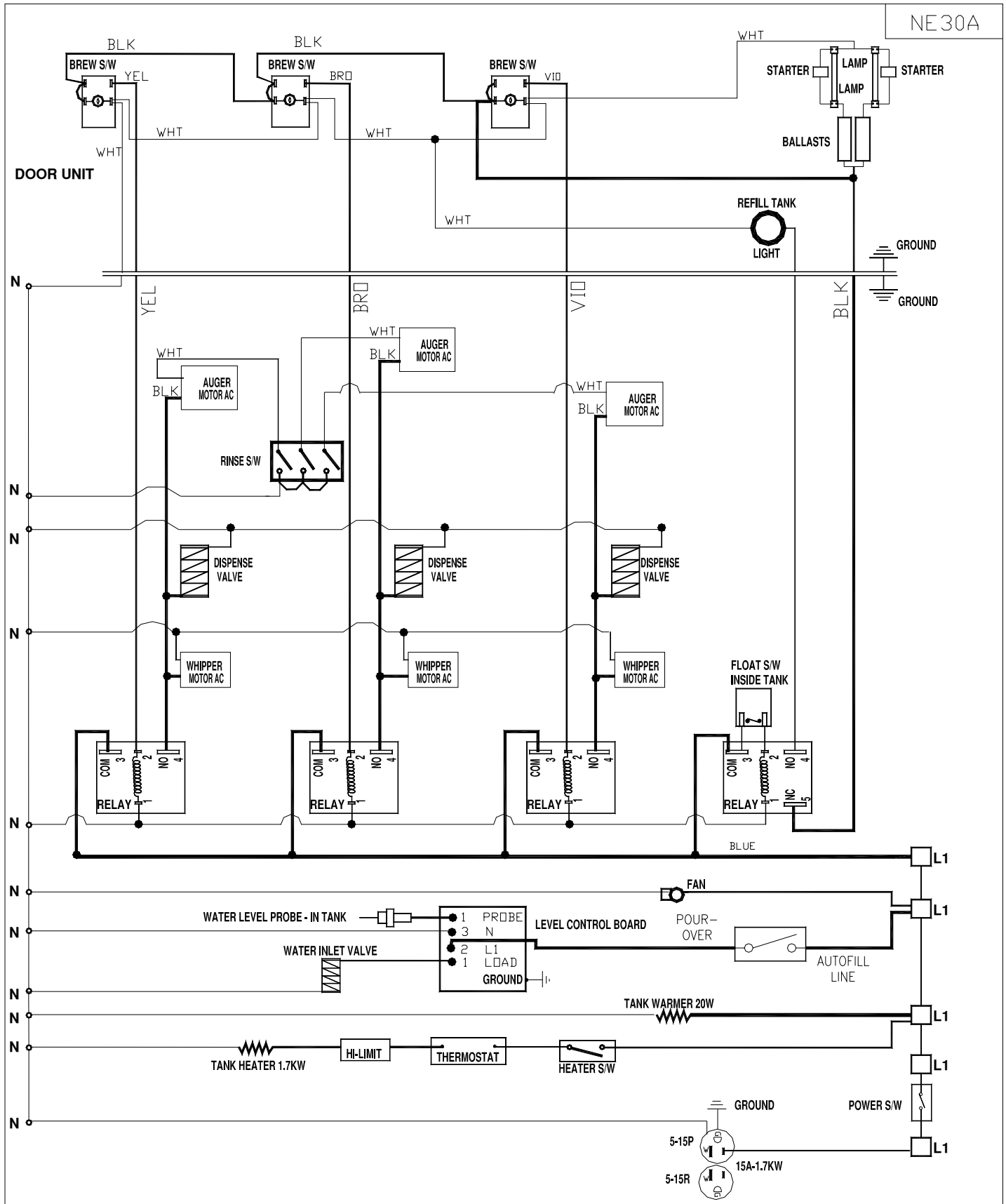

REV	BY	DATE	DESCRIPTION	APPROVED BY	DATE	PART NO. NE30A
MATERIAL:	N/A			DRAWN BY C.G.	DATE 6/17/97	SCALE 1 : 1.01
<b>CECILWARE CORPORATION</b>				43-05 20 AVE. L.I.C. NY 11105		
TITLE: ELECTRICAL DIAGRAM GB3P [120V, 1.7KW, 1 PH, 2 WIRES + GROUND] W/RELAYS						REV.



NE40A

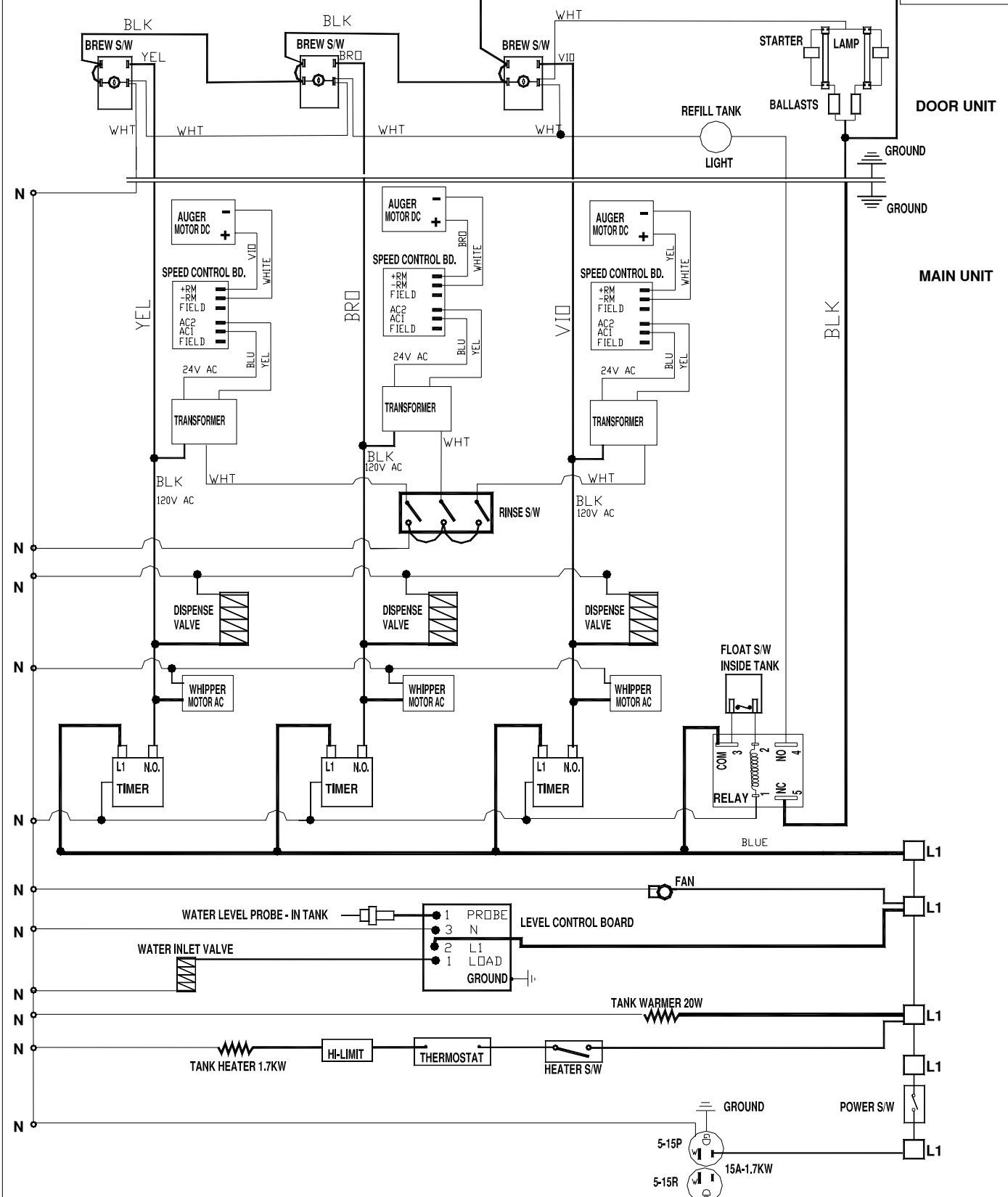

REV	BY	DATE	DESCRIPTION	APPROVED BY	DATE	PART NO. NE40A
MATERIAL:	N/A			DRAWN BY	C.G.	DATE 6/17/97 SCALE N T S
<p align="center"><b>CECILWARE CORPORATION</b></p>				<p align="center">43-05 20 AVE. L.I.C. NY 11105</p>		
<p>TITLE: ELECTRICAL DIAGRAM GB3P [120V, 1.7KW, 1 PH, 2 WIRES + GROUND] W/ TIMERS</p>						REV.

NE41A

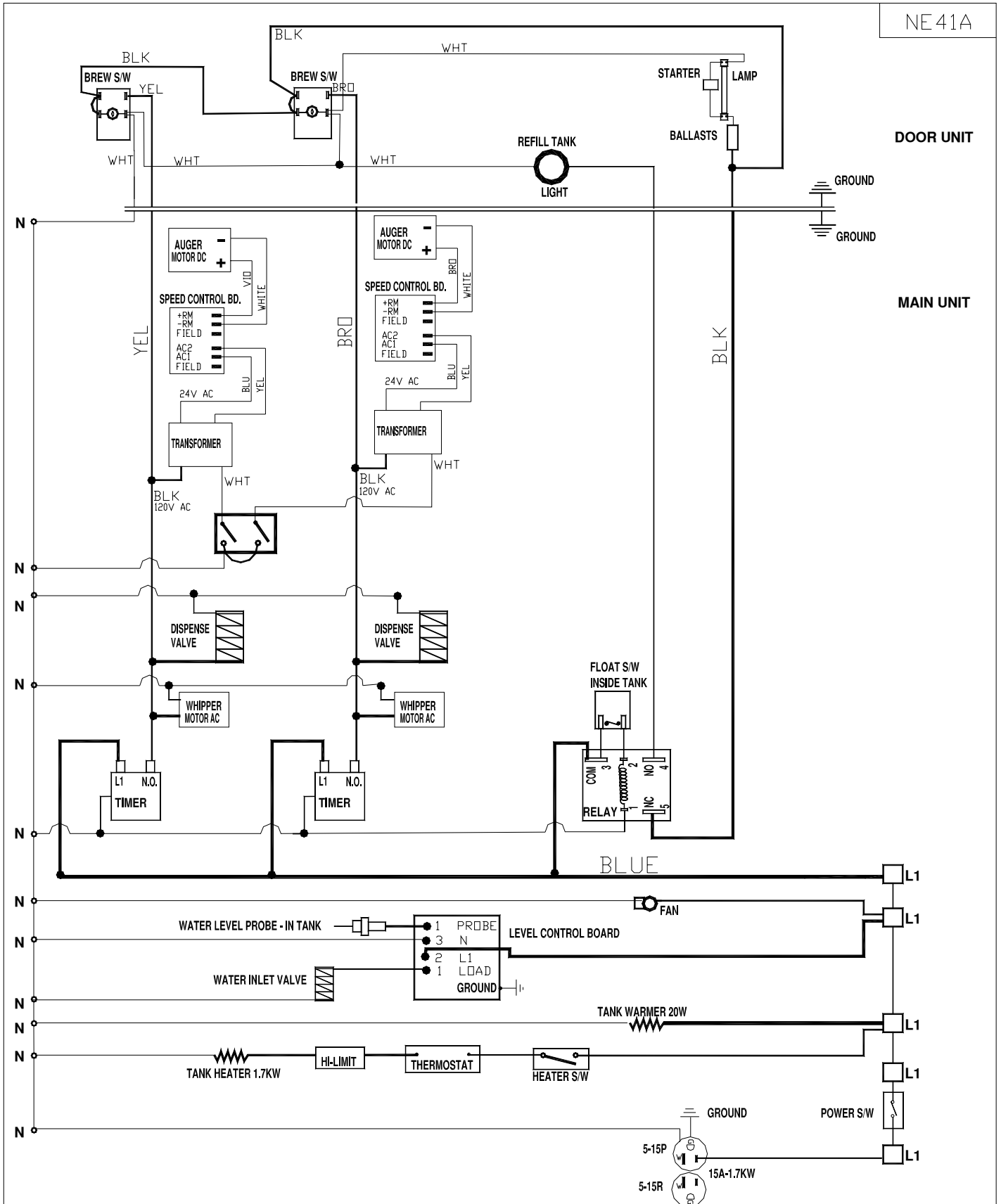

REV	BY	DATE	DESCRIPTION	APPROVED BY	DATE	PART NO. NE41A
MATERIAL:	N/A			DRAWN BY	C.G.	DATE 6/17/97 SCALE N T S
<p>CECILWARE CORPORATION</p>				<p>43-05 20 AVE. L.I.C. NY 11105</p>		
<p>TITLE: ELECTRICAL DIAGRAM GB2P [120V, 1.7KW, 1 PH, 2 WIRES + GROUND] W/ TIMERS</p>						REV.